

CODE OF CONDUCT.

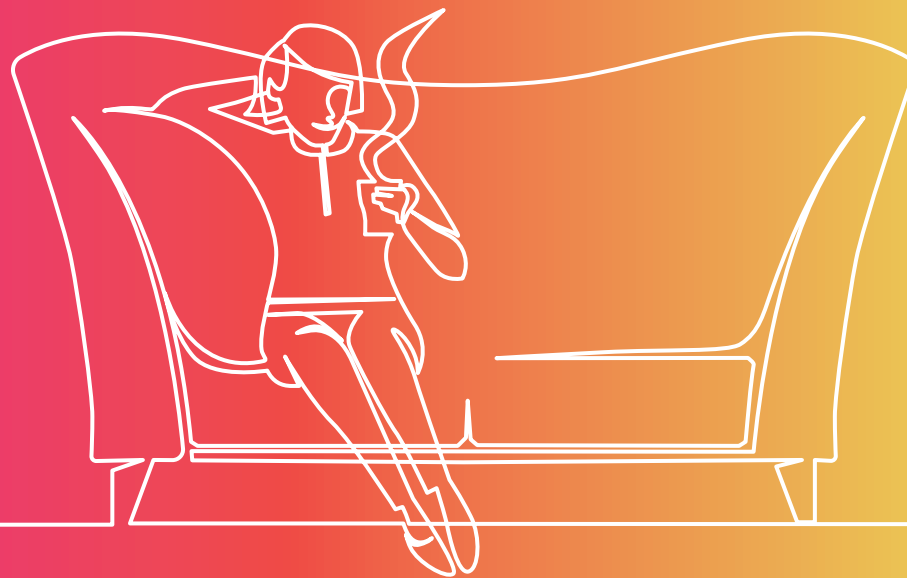

dfs 

dwell

 sofology®



THE SOFA DELIVERY CO
Installation Experts

CODE OF CONDUCT.

Contents

Our big ambition	3
Guided by our values	4
A message from Tim Stacey	5
Key points about the code	6
Making good decisions	7
The principles of our code	8
Health, safety and the environment	12
Working for us	15
Acting responsibly	19

OUR **BIG** **AMBITION.**

Our ambition is to lead sofa retailing in the digital age.

In practice this means that it shouldn't matter how, when, or where a customer chooses to buy a sofa – they'll have the best experience, get the best products and the best value when they shop with us.

We'll only achieve our big ambition by using our values to guide us and by holding ourselves, each other and our partners to the highest possible standards.



GUIDED BY **OUR** **VALUES.**

Our values are there to guide us in everything we do; from the day-to-day stuff, right through to the big decisions we have to make. They've got a special place in our hearts – after all, we created them together.



We treat them as we would our own family, and keep them at the forefront of our minds, because they are at the heart of our group.



We bring our whole selves to work and are confident to speak up. We accept each other for who we are and respect each other as part of the same family.



We play to win for the same team, focused on our shared family ambition. We are bold, brave and welcome challenge as a chance to innovate.

A MESSAGE FROM TIM STACEY.



It doesn't matter where you work in the Group, or what you do, each of us plays an important role in the success of our business.

Our success comes from focusing on our customers, looking after our people and delivering products that people love and value; but it ultimately boils down to making the right decisions day in, day out.

This Code outlines the principles that should guide our decisions and actions. We've made sure it's designed to help us make decisions in the right way, in order to get the best results.

We all have different jobs, and no two days are the same; which makes it difficult to predict all of the different ethical dilemmas that we might encounter. This Code won't have the answers to every question that might crop up while you're at work. It will, however, act as your guide when deciding what the right thing to do is.

Doing the right thing isn't always easy. I want to be clear that your decisions will be fully supported when they've been made in line with this Code and our values. You'll never be punished or penalised for doing the right thing, and we will not tolerate retaliation against anyone who raises a concern.

Please make sure that you're familiar with the principles in this Code. It's important that you consider them if you're ever placed in a difficult or unethical situation.

Tim Stacey
Group CEO

“DOING THE RIGHT THING ISN'T ALWAYS EASY. I WANT TO BE CLEAR THAT YOUR DECISIONS WILL BE FULLY SUPPORTED WHEN THEY'VE BEEN MADE IN LINE WITH THIS CODE AND OUR VALUES.”

KEY POINTS ABOUT THE CODE.



WHY DO WE NEED A CODE?

In a simple and easy-to-understand way, our Code explains the principles that we expect our employees, suppliers and partners to follow. The Code, along with the other policies and guidelines we use across the Group, explains how we should make good decisions in everyday working situations.

WHO NEEDS TO FOLLOW THE CODE?

The Code applies to all employees of the Group, including temporary workers. We also expect all our suppliers, partners and contractors to comply with our, or equivalent, principles and ensure that any other business partners who may be involved in supplying goods or services to the Group are also motivated to follow them.

BREACHES OF THE CODE

We take breaches of the Code very seriously and any reported instances will be thoroughly investigated.

If anyone is found to have broken the Code, then disciplinary action may be taken; up to and including dismissal.

In regards to our suppliers, partners or contractors a breach of the Code may lead to termination of contract and cancellation of orders.

Should any proven breach of the Code be criminal, we will support the appropriate authorities in their prosecutions of the individuals involved, regardless of the jurisdiction.

MAKING GOOD DECISIONS.

Most of the time making good decisions is easy and straightforward. However, sometimes we're put in a situation that may be new or out of the ordinary. It's in these circumstances that doing the right thing isn't always obvious or easy.

In times like this we have to rely on our gut instinct, as well as looking to those we can trust for advice and support. If you're ever faced with a situation or decision where the ethics aren't obvious, you can ask yourself a few questions that might help you make a good choice:

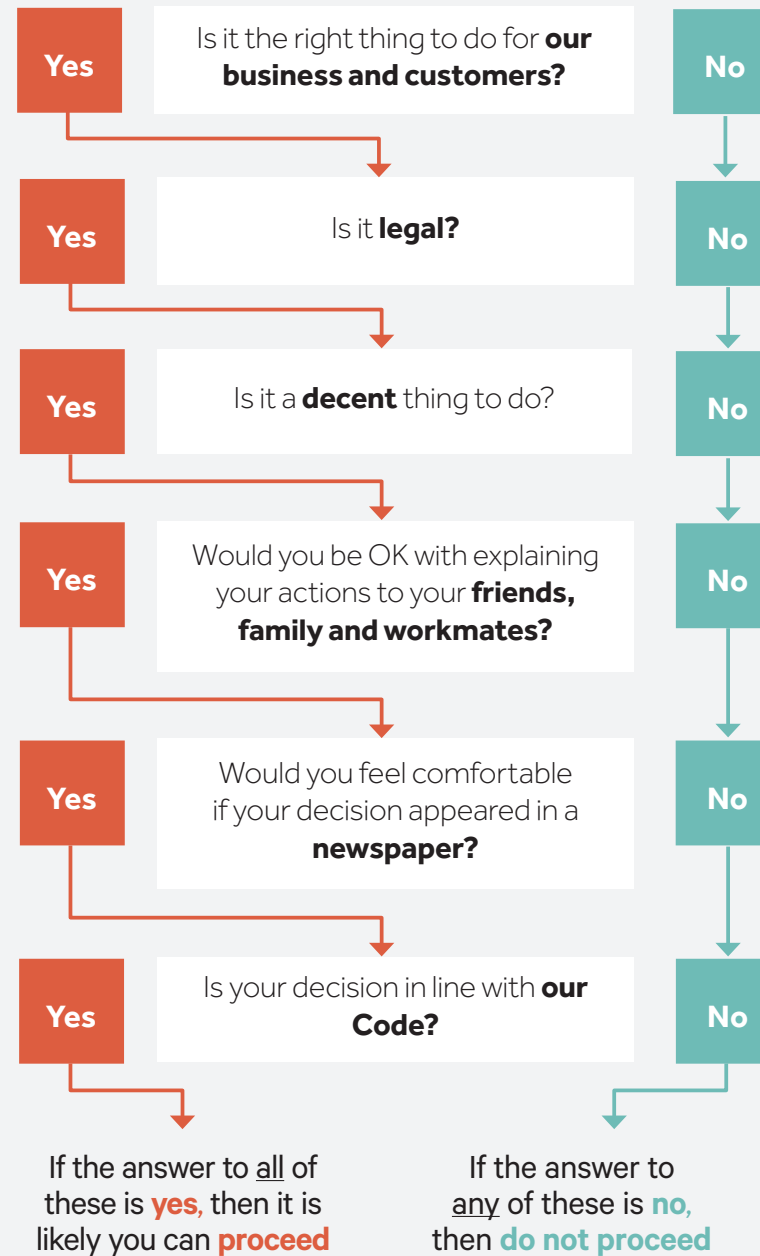

THE PRINCIPLES OF OUR CODE.

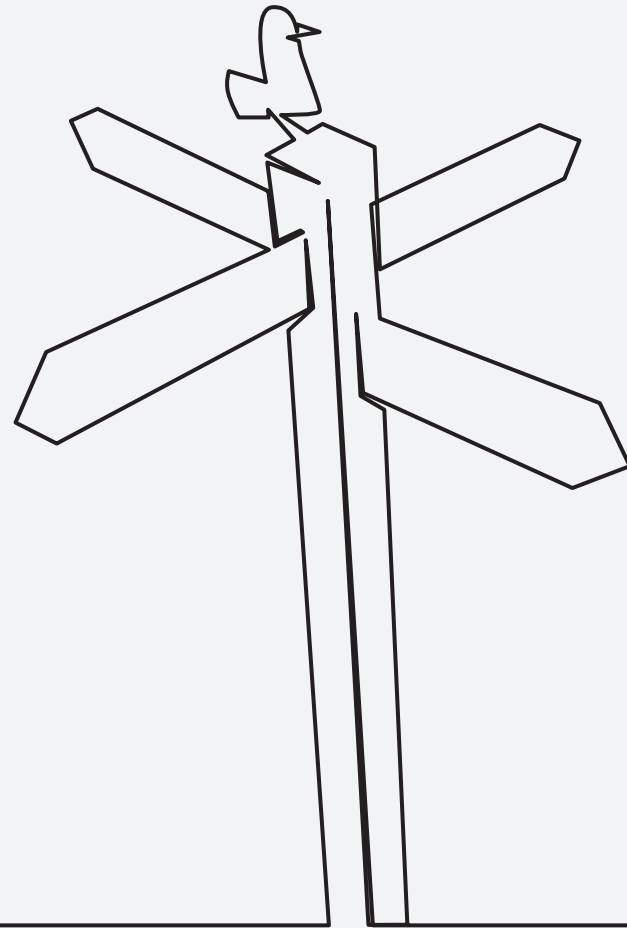

HEALTH, SAFETY AND THE ENVIRONMENT.



HEALTH AND SAFETY:

The safety of our employees, partners and customers always comes first. We'll provide a safe and tidy place of work for our people and those who work with us.

WELLBEING:

We care about the mental and physical wellbeing of our people. We'll support our employees to live happy, healthy lives.

THE ENVIRONMENT:

We will always strive to work in a sustainable way. This means acting responsibly towards the environment and minimising the impact that we have on it – from the packaging we use, through to where and how we source our materials.

WORKING FOR US.

RESPECT AND DIVERSITY:

We respect each other and treat colleagues with consideration and without any form of prejudice, discrimination, bullying or harassment. Our belief is that a diverse workforce makes us stronger; we nurture and celebrate our differences.

WORKPLACE FREEDOM:

Employees have the right to associate freely and communicate openly about working conditions, without fear of repercussions. We respect the right for our people to join a trade union, workers' organisation, or seek representation.

WORKING HOURS:

No one should be required to work more than the maximum regular and overtime hours allowed by law. Any overtime must be voluntary and paid at the agreed contracted rate, or those set by law.

USING COMPANY PROPERTY:

We respect company property, keep it safe and always use it responsibly.

BRIBERY AND CORRUPTION:

We will not accept bribery or corruption; in any form, or in any place. We do not offer, give, or take a bribe or inappropriate payment, either directly or indirectly.

GIFTS AND HOSPITALITY:

Giving or accepting a gift or hospitality should only be done if it can be proved to be of small and modest value. They should never influence the decisions we take.

CONFLICTS OF INTEREST:

All potential, or actual conflicts of interest should be declared and managed. This will ensure they never stop us from making objective decisions.



ACTING RESPONSIBLY.

OUR CUSTOMERS:

We exist for, and because of, our customers. We're always seeking to provide excellent service, great value and, of course, products that our customers love.

OUR PARTNERS AND SUPPLIERS:

We're fair and open in our dealings with suppliers and contractors. We respect their role in our business and require their commitment to equivalent standards and practices.

OUR REGULATORS:

We take our regulatory responsibilities seriously and always deal with our regulators in an open and co-operative way.

CHILD LABOUR AND MODERN SLAVERY:

We do not accept or tolerate modern slavery or child labour in our Company or any organisation we deal with.

SAFEGUARDING DATA:

Regardless of whether it's personal, company or third-party data and information, we always treat and use it responsibly. We're cautious and considered when we talk about our work online, or on social media.

BUSINESS TRANSACTIONS AND INFORMATION:

All business records, information and transactions must be recorded accurately and honestly. We're steadfast in our approach to preventing any kind of fraud or financial crime.

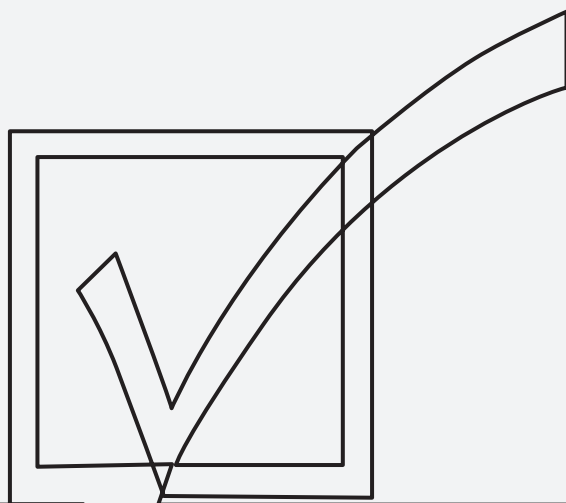

HEALTH, SAFETY AND THE ENVIRONMENT.



THE SAFETY, MENTAL HEALTH AND PHYSICAL WELLBEING **OF ALL OUR PEOPLE COMES FIRST.**



HEALTH AND SAFETY

The principle: The safety of our employees, partners and customers always comes first. We'll provide a safe and tidy place of work for our people and those who work with us.

What this means in practice:

- We have the right health and safety processes and systems in place to keep our people and customers safe
- We always look at how we can improve health and safety
- All employees look out for their own health and safety, as well as that of their workmates
- We only carry out work if it's safe to do so and when we're trained, competent and authorised to do it
- If something looks unsafe, or if we know of any unsafe practices, we report them
- We don't tolerate the possession, distribution or use of drugs or alcohol in the workplace
- We make sure that the sites and offices we work in are kept safe and secure

WELLBEING

The principle: We care about the mental and physical wellbeing of our people. We'll support our employees to live happy, healthy lives.

What this means in practice:

- Our working environments and ways of working aim to support a healthy work-life balance
- We support employees to live a healthy and balanced way of life
- We recognise the importance of mental health and wellbeing and have the right processes and support systems in place for our employees
- We make provision for our people to be physically active and encourage them to get involved in health and wellbeing activities
- Where practical and appropriate we raise awareness of key issues in the workplace, such as smoking cessation, healthy eating and education on the risks of alcohol
- We always promote ways to stay mentally and emotionally healthy

WE ALWAYS STRIVE TO
**ACT RESPONSIBLY
TOWARDS THE
ENVIRONMENT**
AND MINIMISE THE
IMPACT THAT WE
HAVE ON IT.

THE ENVIRONMENT

The principle: We will always strive to work in a sustainable way. This means acting responsibly towards the environment and minimising the impact that we have on it – from the packaging we use, through to where and how we source our materials.

What this means in practice:

- We seek to drive sustainability through our workplaces and our supply chain
- We always look at how we can reduce the impact we have on the world, including the communities in which we work and source our materials from

- We recycle and reuse as much as we can. What we can't is disposed of responsibly
- We are proactively reducing the amount of emissions we produce from the cars, lorries and vans that we use to do business
- We comply with environmental laws and report our environmental performance in a transparent and easy-to-understand way
- We encourage our people, partners and suppliers to work in a sustainable way that protects and nurtures the environment



WORKING FOR US.



OUR BELIEF IS THAT A DIVERSE WORKFORCE MAKES US STRONGER; **WE NURTURE AND CELEBRATE OUR DIFFERENCES.**

RESPECT AND DIVERSITY

The principle: We respect each other and treat colleagues with consideration and without any form of prejudice, discrimination, bullying or harassment. Our belief is that a diverse workforce makes us stronger; we nurture and celebrate our differences.

What this means in practice:

- Our workplaces are inclusive and diverse
- We always work hard to promote equal opportunities and ensure that employees are treated fairly and with respect
- Any and all forms of bullying, harassment or discrimination will not be tolerated
- Our recruitment policies and practices are transparent and we always promote on merit
- We listen hard to what our employees have to say, seeking their opinions and involvement in how we grow and improve our business
- We respect human rights in our business and our supply chain and do not tolerate modern slavery anywhere

WORKPLACE FREEDOM

The principle: Employees have the right to associate freely and communicate openly about working conditions, without fear of repercussions. We respect the right for our people to join a trade union, workers' organisation, or seek representation.

What this means in practice:

- We respect the rights to freedom of association
- We encourage good conversations between all employees about how to improve the workplace and how we work
- We are committed to respect the right of employees to join a trade union or workers' organisation

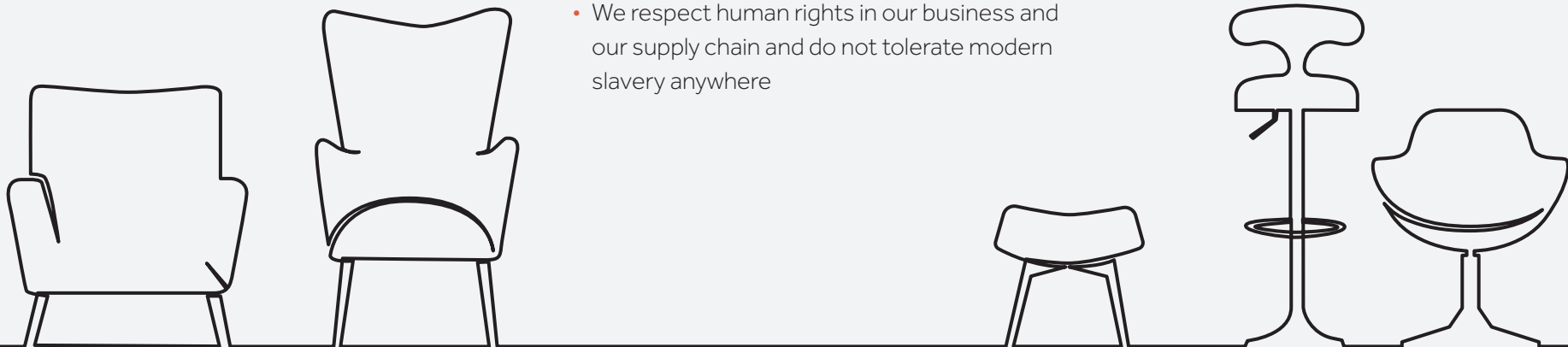

WORKING HOURS

The principle: No one should be required to work more than the maximum regular and overtime hours allowed by law. Any overtime must be voluntary and paid at the agreed contracted rate, or those set by law.

What this means in practice:

- We comply with all workplace legislation on the maximum number of hours that employees can work
- We never coerce or pressure employees to do overtime and will always pay employees in line with their contracted rates

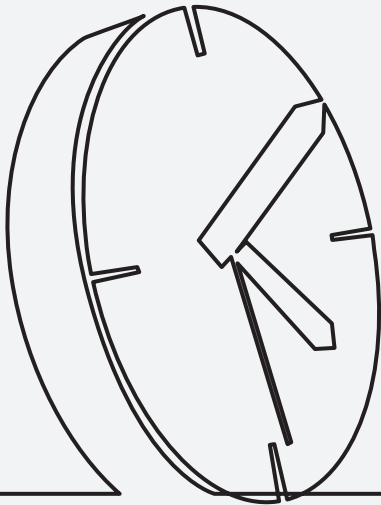

USING COMPANY PROPERTY

The principle: We respect company property, keep it safe and always use it responsibly.

What this means in practice:

- We keep company property and equipment safe and secure – including intellectual property
- Employees never use company equipment or properties to access, keep, send or copy data or information that may be considered obscene, inappropriate or offensive

BRIBERY AND CORRUPTION

The principle: We will not accept bribery or corruption; in any form, or in any place. We do not offer, give, or take a bribe or inappropriate payment, either directly or indirectly.

What this means in practice:

- Offering, giving, taking or promising things that may influence, or affect an organisation or individual in order to gain business, or an advantage is not allowed in any form
- Accepting or offering a bribe/kickback payment of any kind is prohibited; a bribe doesn't have to be successful to be corrupt
- We will never use our charity or sponsorship activities to gain an unfair advantage
- We expect all employees, partners and suppliers to report any breaches, or suspected bribes or corrupt behaviour

GIVING OR ACCEPTING A GIFT SHOULD NEVER **INFLUENCE THE DECISIONS WE TAKE.**

GIFTS AND HOSPITALITY

The principle: Giving or accepting a gift or hospitality should only be done if it can be proved to be of small and modest value. They should never influence the decisions we take.

What this means in practice:

- We don't offer or accept gifts or hospitality as part of contract negotiations or sales transactions
- Any gifts given or received are modest in value and recorded appropriately

CONFLICTS OF INTEREST

The principle: All potential or actual conflicts of interest should be declared and managed. This will ensure they never stop us from making objective decisions.

What this mean in practice:

- We don't put ourselves in a position where our knowledge or relationships compromises our decision
- All personal conflicts of interest are declared – even if they are potential in nature
- Insider trading, either direct or indirect, is strictly prohibited by law



ACTING RESPONSIBLY.

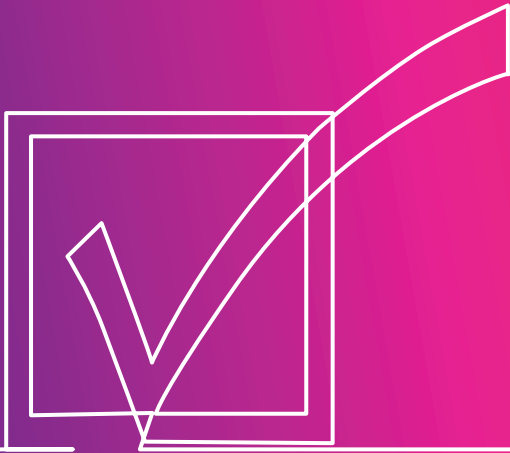

WE EXIST FOR OUR CUSTOMERS AND ARE ALWAYS SEEKING TO **PROVIDE EXCELLENT SERVICE, GREAT VALUE AND PRODUCTS THAT OUR CUSTOMERS LOVE.**

OUR CUSTOMERS

The principle: We exist for, and because of, our customers. We're always seeking to provide excellent service, great value and, of course, products that our customers love.

What this means in practice

- We aim to design quality products and services that customers love
- We have a keen eye for style and fashion and keep our product ranges updated to reflect changes in our customers' tastes and needs
- We always offer customers the best products and great value with a fair and transparent approach to pricing
- We always explain how customers can pay for our products and if they use credit we find a loan term and repayment that suits them
- Optional products and services are always clearly explained with no pressure to buy
- We listen to our customers and make improvements and changes based on what they have to say

OUR PARTNERS AND SUPPLIERS

The principle: We're fair and open in our dealings with suppliers and partners. We respect their role in our business and require their commitment to equivalent standards and practices.

What this means in practice:

- We have strong and transparent processes to select and manage our suppliers and partners
- Our expectation is that our partners, suppliers and contractors will uphold the principles in this Code, or equivalent standards
- We expect all of our suppliers and partners working at our sites to adhere to our Health and Safety standards and policies
- Partners, suppliers and other organisations we work with are asked to protect human rights and provide good working conditions

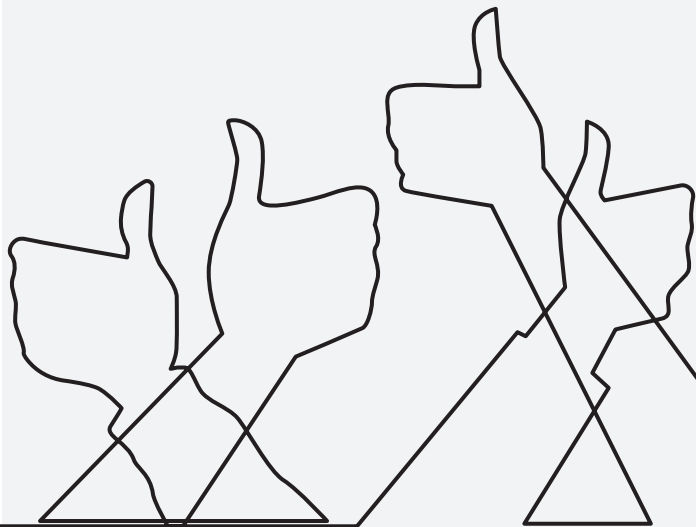

WE'RE OPEN WITH OUR REGULATORS AND ALWAYS FULLY CO-OPERATE, TELLING THEM IF SOMETHING GOES WRONG.

OUR REGULATORS

The principle: We take our regulatory responsibilities seriously and always deal with our regulators in an open and co-operative way.

What this means in practice:

- We always act with integrity and do the right thing for our customers
- We act with due care, skill and diligence, taking time to talk customers through what decisions they can take and offering regulated products in line with our training
- We're open with our regulators and always fully cooperate with them, meaning we tell them if something goes wrong
- We put the interests of our customers first and treat them fairly, we always seek to understand what our customers want and treat them as we would expect to be treated
- We observe proper standards of market conduct, this means meeting our customers' expectations, providing the best products and best customer experience every time

CHILD LABOUR AND MODERN SLAVERY

The principle: We do not accept or tolerate modern slavery or child labour in our Company or any organisation we deal with.

What this means in practice:

- We do not tolerate any children under the age of 15 working for us
- If national laws or regulations allow children between the ages of 13 and 15 to perform light work, such work is not permitted under any circumstances if it in any way prevents them from completing compulsory schooling or training, or if the work is in any way harmful to their health, development or wellbeing
- Modern slavery isn't accepted in our Company, or in any part of our supply chain – either in the UK or abroad. We are committed to reporting openly on this issue

WE ENSURE THAT ALL OUR DATA IS **STORED AND PROCESSED SECURELY, MAINTAINING CONFIDENTIALITY AT ALL TIMES.**

SAFEGUARDING DATA

The principle: Regardless of whether its personal, company or third-party data and information, we always treat and use it responsibly. We're cautious and considered when we talk about our work online, or on social media.

What this means in practice:

- We comply fully with the law relating to data protection
- We ensure that all the data we need to run our business is stored and processed securely, maintaining confidentiality at all times
- All third-party requests for information and data, including media enquiries, are responded to appropriately and by the right people and teams
- Social media is used responsibly and all views that are shared and expressed are independent of the Group

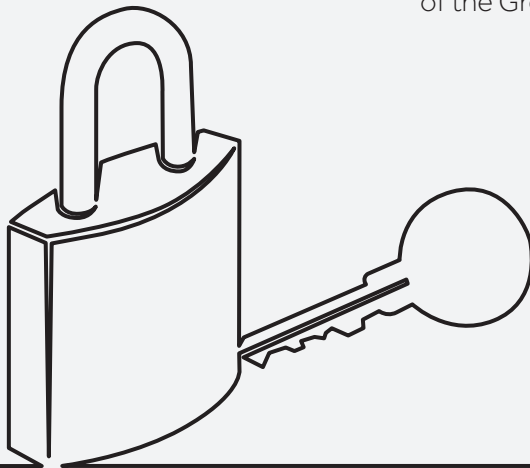

BUSINESS TRANSACTIONS AND INFORMATION

The principle: All business records, information and transactions must be recorded accurately and honestly. We're steadfast in our approach to preventing any kind of fraud or financial crime.

What this means in practice:

- We have robust controls in place to prevent and detect any form of fraud or money laundering
- The records of our business dealings and finances are accurate and well maintained
- If we suspect any kind of irregularity in our finances, they are reported straight away to the management team
- Timesheets and expenses that are submitted for payment are accurate and timely

WHISTLEBLOWING HELPLINE

0333 212 3535

The Whistleblowing Helpline is here for you to report any potentially unsafe, unethical or unlawful conduct.

If you do not feel comfortable about raising your concerns directly to management, then you can report your concerns by calling this external and confidential telephone number.

You will not be required to identify yourself, but you will be asked certain information sufficient to enable us to investigate the report.



dfs 

dwell

 sofology®



THE SOFA DELIVERY CO
Installation Experts